

ARCTIKO LFF 270

true cooling specialists



SMART FRIDGE AND FREEZER IN ONE CABINET, MAKES IT A PERFECT SOLUTION FOR LABORATORIES WITH LIMITED SPACE DUE TO THE SMALL FOOTPRINT.

With air forced cooling and automatic defrost which will save time to focus on what's most important and store the samples most reliable.

▶ INDEPENDENT & LESS FOOTPRINT

The LFF comes with two controllers allowing you to set and operate them as two independent units. With separate locks and passwords, it provides the ability to restrict access to storage and settings, in case the unit have multiple users.

The unit is in effect of two fully independent units each with it's own compressor, cooling circuit and controller – allowing to turn off one of the compartments in case that they are not in use for some time.

▶ AUTOMATIC DEFROST

With Arctiko's automatic defrost system it's not required to remove samples prior to defrosting, saving you valuable time to focus on what matter the most and at the same time stores the samples safely.

▶ EXCEPTIONAL COOLING

Arctiko has combined the high quality cooling performance created by air-forced cooling and automatic defrosting.

The results meet the more stringent requirements for lower power consumption, more precise cooling uniformity, need for temperature and alarm surveillance, documentation and validation, making the LFF range the perfect solution for biomedical storage.



LFF 270*



FORCED AIR COOLING



FILTERLESS CONSTRUCTION



AVAILABLE IN ATEX

* The pictures shown are for reference only, actual product size may vary. Please read the dimensions of the product in the specifications.

The ARCTIKO LFF 270 model supports following optional features:

- GSM alarm module
- Temperature chart recorder
- Shelves (perforated, wire stainless steel, plastic coated)
- Stainless steel drawers
- Modbus adapter for G214 controller
- Voltage converter
- Voltage stabilizer
- LED Light

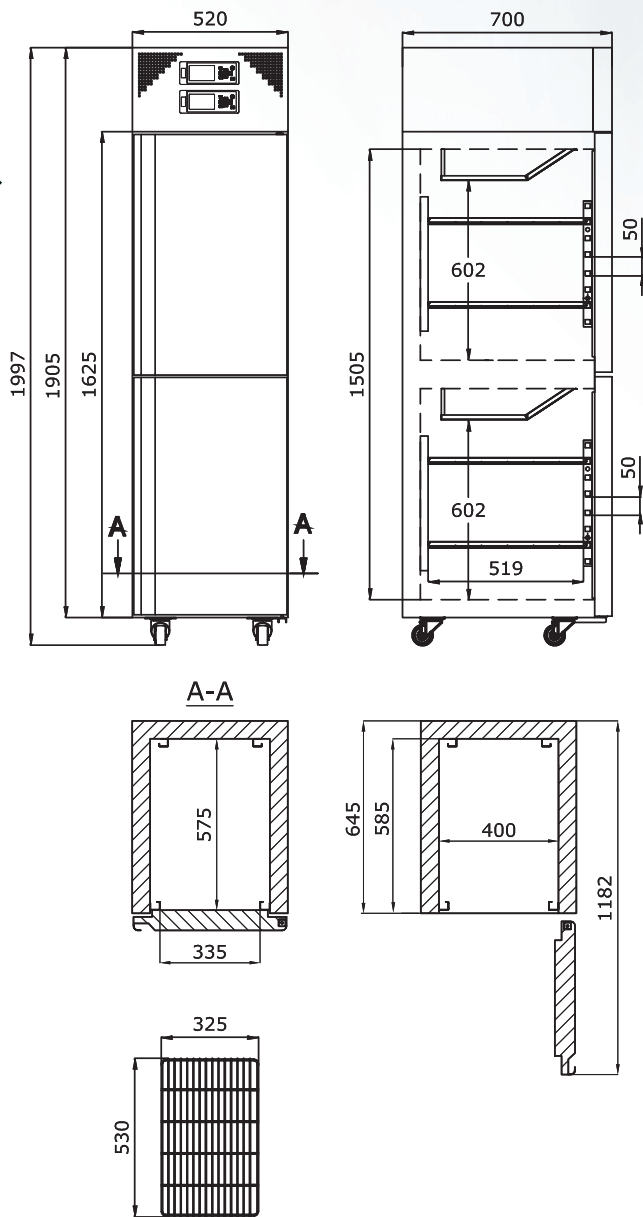

MODEL	LFF 270
Item code	DAI 0235
Temperature range (°C)	+1 / +10 -10 / -30
Max. ambient temperature (°C)	32
Capacity (L)	161 / 161
Exterior dimensions WxDxH (mm)	520x700x1997
Interior dimensions WxDxH (mm)	2x(400x575x700)
Weight (KG)	120
Insulation (mm)	60
Cooling technology	forced air
Controller Model / probe type	G214 / PT1000
Power supply (V)	230*
Frequency (Hz)	50/60
Power consumption (kWh/24h)	11.4
AMP (A)	5.8
Power (Watt)	728
Horse power (HP)	1/10 + 1/8
Alarm display as text - not codes	yes
Visual / acoustic alarm	yes / yes
Power failure alarm	yes
Adjustable high / low temperature alarm	yes / yes
Open door alarm	yes
Probe failure alarm	yes
Low battery alarm	yes
Compressor failure alarm	no
Battery backup for alarms (approx. hrs.)	72
Voltage free contact for remote alarm (e.g. GSM alarm module)	yes
Electronic data logger	yes
RS 485 port	yes
USB port for software update & data download	yes
Temperature chart recorder	optional
Display type	4,3" with touch buttons
Number of optional reference probes	2
Password protection for turning unit on / off	yes
Temperature graph on display	yes
Automatic defrost	yes
Antifreeze function	no
Vacuum release port	no
Access port for external probe etc. (int. diameter mm)	optional
Light	no
Lock with key	yes
Castors (total pcs) / castors with brake (pcs)	4 / 2
Fixed feet (pcs) / levelling feet (pcs)	no
Sub lids / inner doors (pcs)	no
Reversible door(s)	yes
Fixed shelves (pcs) / adjustable shelves (pcs)	0 / 4
Max. no. of shelves (pcs) / recommended max. no. of shelves (pcs)	16 / 8
Max. load per shelf (kg)	30
Adjustable drawers (pcs)	optional
Max. no. of adjustable drawers (pcs)	6
Max. load per adjustable drawer (kg)	30
Number of compressors	2
Refrigerant	R290
Interior cabinet material	stainless steel
Exterior cabinet material	painted steel
Colour (exterior cabinet)	white
Foam type	polyurethane
VIP vacuum insulated panels	no
Shipping weight (kg)	175
Shipping dimensions WxDxH (cm)	83x67x220
Shipping volume (m³)	1,22

*110V/60Hz available as option

