

ARCTIKO Flexaline PRE 125-US

true cooling specialists



BIOMEDICAL REFRIGERATOR

Introducing the PRE 125-US from our Flexaline series, the epitome of advanced design in biomedical refrigeration. This meticulously crafted glass door refrigerator is specifically engineered to meet the stringent demands of biomedical applications. Equipped with state-of-the-art temperature controls and cutting-edge technology, these refrigerators play a crucial role in safeguarding the integrity of medical supplies and advancing scientific accomplishments.

ARCTIKO's Flexaline is unique in this field with an integrated data logger for extra security.

▶ ENERGY STAR CERTIFIED

Energy Star certified, guaranteeing exceptional energy efficiency and reduced environmental impact, while maintaining superior performance in temperature-sensitive storage applications.

▶ INTEGRATED DATA LOGGER

Integrated data logger, providing accurate monitoring of temperature conditions. This allows for precise data recording and analysis, ensuring optimal storage conditions for critical samples and maintaining regulatory compliance.

▶ FORCED AIR COOLING

Forced air cooling provides excellent temperature stability. Forcing the airflow around the stored items ensures quick temperature recovery after door openings.

▶ KEY LOCK SECURITY

Equipped with a secure key lock, providing an added layer of protection for valuable contents and preventing unauthorized access. This feature ensures the integrity and confidentiality of stored items, making it ideal for environments where security is paramount.

▶ SNAP/EPA COMPLIANT REFRIGERANT

Utilizes refrigerants that are fully compliant with the Environmental Protection Agency (EPA) and the Significant New Alternatives Policy (SNAP) regulations, ensuring environmentally responsible operation without compromising performance or safety.



PRE 125-US



Microprocessor controller with visual and acoustic alarms, high/low temperature alarm, open door alarm, and integrated data logger.



Adjustable shelves for flexible storage.



All models feature durable and cost-saving, customizable LED lighting for improved sample visibility.



DATA LOGGER



USB PORT



FORCED AIR COOLING



ADJUSTABLE SHELVES



VARIOUS SAFETY FEATURES

The ARCTIKO Flexaline series includes the following features, and more:

- Energy star certified
- SNAP/EPA compliant refrigerant
- Built-in data logger
- Key lock
- Microprocessor controller
- Adjustable shelves
- Automatic defrost
- Access port for external sensor
- Anti freeze thermostat

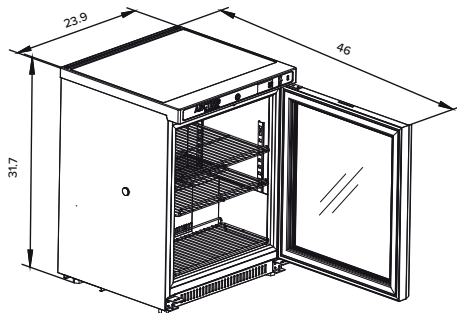
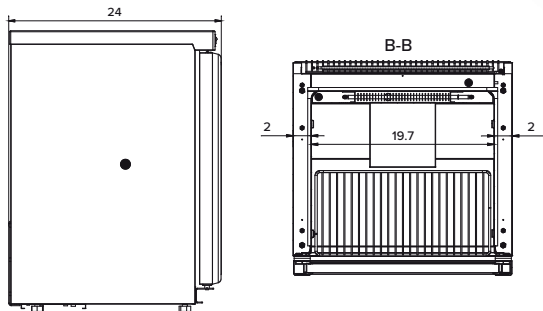
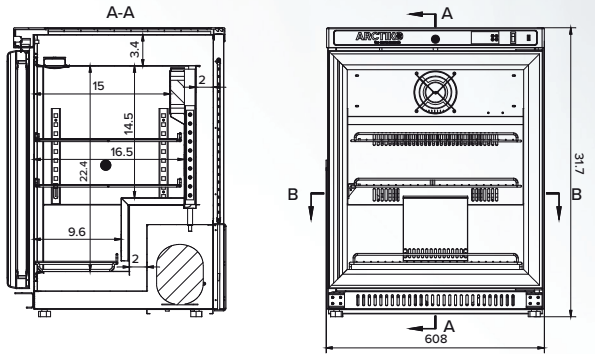

| MODEL | PRE 125-US | |
|------------------------------------|---|---------------------------------|
| Main specifications | Item code | 1900020-01 |
| | Temperature range (°C) | +2 / +8 °C |
| | Max Ambient temperature (°C) | +32 °C |
| | Capacity (L) | 109 |
| | Capacity (cu.FT) | 3.8 |
| | Exterior dimensions WxDxH (inches) | 24 x 24 x 32 |
| | Interior dimensions WxDxH (inches) | 20 x 17 x 22 |
| | Weight (lb) | 93 |
| | Insulation (Inches) | 1.97 |
| | Cooling technology | Forced Air |
| Controller model / probe type | Honker / NTC | |
| Power | Power supply (V) | 110 |
| | Plug Type | 5-15P |
| | Cord Length | 2.0 m |
| | Frequency (Hz) | 60 |
| | Power consumption (kWh/24h) | 1.5 |
| | AMP (A) | 2.0 |
| | Power (Watt) | 102 |
| Horsepower (HP) | 1/7 | |
| Alarm functions | Visual / acoustic alarm | Yes / Yes |
| | Power failure alarm | Yes |
| | Adjustable high / low-temperature alarm | Yes / Yes |
| | Open door alarm | Yes |
| | Probe failure alarm | Yes |
| | Low battery alarm | Yes |
| Data logging & external connection | Voltage-free contact for remote alarm (e.g. GSM alarm module) | Yes |
| | Electronic data logger | Yes |
| | USB port for software update & data download | Yes |
| Display features | Display type | Digital |
| Other features | Automatic defrost | Yes |
| | Antifreeze function | Yes |
| | Access port for external probe etc. (int. diameter "In") | 0.79 |
| | Light | Yes |
| | Lock with key | Yes |
| | Fixed feet (pcs) / levelling feet (pcs) | 4 / 4 |
| | Reversible door(s) | Yes |
| | Fixed shelves (pcs) / adjustable shelves (pcs) | 0 / 3 |
| | Max. no. of shelves / recommended max. no. of shelves (pcs) | 3 / 3 |
| Max load per shelf (lb) | 44 | |
| Refrigeration & cabinet | Number of compressors | 1 |
| | Refrigerant | R600a |
| | Interior cabinet material | Pre-coated aluminum sheet |
| | Exterior cabinet material | Galvanized steel powder coating |
| | Colour (exterior cabinet) | White |
| Shipping | Foam type | Cyclopentane |
| Shipping | Shipping weight (lb) | 114.6 |
| | Shipping dimensions WxDxH (inches) | 26 x 26 x 37 |
| | Shipping volume (cu.FT) | 14.12 |