

# ARCTIKO Flexaline LFE 60-US

true cooling specialists



## BIOMEDICAL FREEZER

ARCTIKO's Flexaline LFE 60-US, a counter-top biomedical freezer designed to meet the high standards of biomedical applications. With an upright design and a compact 2.3 ft<sup>3</sup> capacity, this freezer ensures precise temperature control within the range of -10°C to -25°C. With its low energy consumption, our eco-friendly Flexaline series offers an excellent level of flexibility, security, and reliability.

### ► ENERGY STAR CERTIFIED

Energy Star certified, guaranteeing exceptional energy efficiency and reduced environmental impact, while maintaining superior performance in temperature-sensitive storage applications.

### ► INTEGRATED DATA LOGGER

Integrated data logger, providing accurate monitoring of temperature conditions. This allows for precise data recording and analysis, ensuring optimal storage conditions for critical samples and maintaining regulatory compliance.

### ► KEY LOCK SECURITY

Equipped with a secure key lock, providing an added layer of protection for valuable contents and preventing unauthorized access. This feature ensures the integrity and confidentiality of stored items, making it ideal for environments where security is paramount.

### ► SNAP/EPA COMPLIANT REFRIGERANT

Utilizes refrigerants that are fully compliant with the Environmental Protection Agency (EPA) and the Significant New Alternatives Policy (SNAP) regulations, ensuring environmentally responsible operation without compromising performance or safety.



LFE 60-US



The digital controller features visual and acoustic alarms, high/low-temperature alarms, open-door alarms and a data logger.



The shelves are easily adjustable to offer the best flexibility for your storage needs.



All models in our Flexaline range feature durable, cost saving LED lighting for better overview of your samples.



DATA LOGGER



USB PORT



ADJUSTABLE SHELVES



VARIOUS SAFETY FEATURES

\* The pictures shown are for reference only, actual product size may vary. Please read the dimensions of the product in the specifications.

The ARCTIKO Flexaline series includes the following features, and more:

- Energy star certified
- SNAP/EPA compliant refrigerant
- Built-in data logger
- Key lock
- Microprocessor controller
- Adjustable shelves
- Access port for external sensor
- Anti freeze thermostat

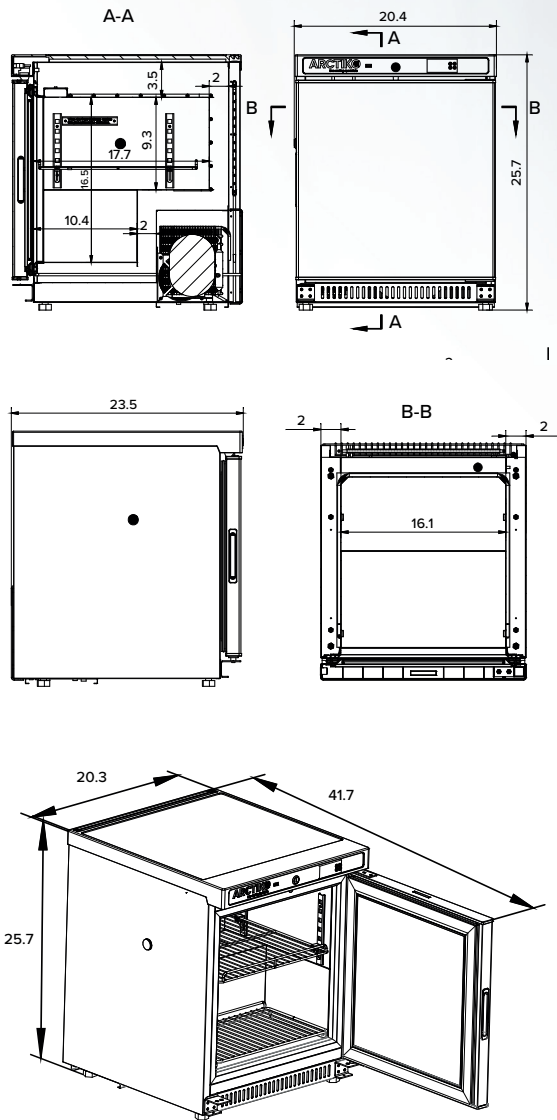

MODEL		LFE 60-US
Main specifications	Item code	1900039-01
	Temperature range (°C)	-25°C to -10°C
	Max Ambient temperature (°C)	+32 °C
	Capacity (L)	65
	Capacity (cu.FT)	2.29
	Exterior dimensions WxDxH (inches)	20 x 24 x 26
	Interior dimensions WxDxH (inches)	16 x 18 x 17
	Weight (lb)	70.5
	Insulation (Inches)	1.97
	Cooling technology	Direct Cooling
Controller model / probe type	Honker / NTC	
Power	Power supply (V)	110
	Plug Type	5-15P
	Cord Length	2.0 m
	Frequency (Hz)	60
	Power consumption (kWh/24h)	1.2
	AMP (A)	2.0
	Power (Watt)	70
Horsepower (HP)	1/10	
Alarm functions	Visual / acoustic alarm	Yes / Yes
	Power failure alarm	Yes
	Adjustable high / low-temperature alarm	Yes / Yes
	Open door alarm	Yes
	Probe failure alarm	Yes
	Low battery alarm	Yes
Data logging & external connection	Voltage-free contact for remote alarm (e.g. GSM alarm module)	Yes
	Electronic data logger	Yes
	USB port for software update & data download	Yes
Display features	Display type	Digital
Other features	Access port for external probe etc. (int. diameter "in")	0.79
	Light	Yes
	Lock with key	Yes
	Fixed feet (pcs) / levelling feet (pcs)	4 / 4
	Reversible door(s)	Yes
	Fixed shelves (pcs) / adjustable shelves (pcs)	0 / 2
	Max. no. of shelves / recommended max. no. of shelves (pcs)	2 / 2
Max load per shelf (lb)	33	
Refrigeration & cabinet	Number of compressors	1
	Refrigerant	R600a
	Interior cabinet material	Pre-coated aluminum sheet
	Exterior cabinet material	Galvanized steel powder coating
	Color (exterior cabinet)	White
Foam type	Cyclopentane	
Shipping	Shipping weight (lb)	88
	Shipping dimensions WxDxH (inches)	22 x 26 x 31
	Shipping volume (cu.FT)	10.59

