

ARCTIKO Flexaline LRE 125

true cooling specialists



BIOMEDICAL REFRIGERATOR

The LRE 125 under counter refrigerator is a compact solution for pharmaceutical applications. Designed to store temperature sensitive biological materials, vaccines and medications to ensure their safety and integrity. With precise temperature controls and advanced technologies, these refrigerators play a crucial role in preserving the efficacy of medical supplies and contributing to scientific advancements.

ARCTIKO's Flexaline is unique in this field with an integrated data logger for extra security.

► ENERGY STAR CERTIFIED

Energy Star certified, guaranteeing exceptional energy efficiency and reduced environmental impact, while maintaining superior performance in temperature-sensitive storage applications.

► INTEGRATED DATA LOGGER

Integrated data logger, providing accurate monitoring of temperature conditions. This allows for precise data recording and analysis, ensuring optimal storage conditions for critical samples and maintaining regulatory compliance.

► FORCED AIR COOLING

Forced air cooling provides excellent temperature stability. Forcing the airflow around the stored items ensures quick temperature recovery after door openings.

► KEY LOCK SECURITY

Equipped with a secure key lock, providing an added layer of protection for valuable contents and preventing unauthorized access. This feature ensures the integrity and confidentiality of stored items, making it ideal for environments where security is paramount.

► SNAP/EPA COMPLIANT REFRIGERANT

Utilizes refrigerants that are fully compliant with the Environmental Protection Agency (EPA) and the Significant New Alternatives Policy (SNAP) regulations, ensuring environmentally responsible operation without compromising performance or safety.

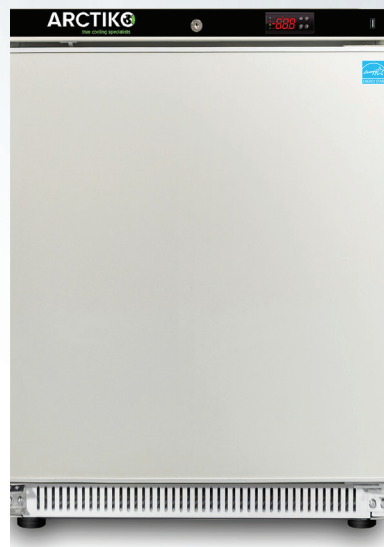

LRE 125



Microprocessor controller with visual and acoustic alarms, high/low temperature alarm, open door alarm, and integrated data logger.



Adjustable shelves for flexible storage.



All models feature durable and cost-saving, customizable LED lighting for improved sample visibility.



DATA LOGGER



USB PORT



FORCED AIR COOLING



ADJUSTABLE SHELVES



VARIOUS SAFETY FEATURES

* The pictures shown are for reference only, actual product size may vary. Please read the dimensions of the product in the specifications.

The ARCTIKO Flexaline series includes the following features, and more:

- Energy star certified
- SNAP/EPA compliant refrigerant
- Built-in data logger
- Key lock
- Microprocessor controller
- Adjustable shelves
- Automatic defrost
- Access port for external sensor
- Anti freeze thermostat

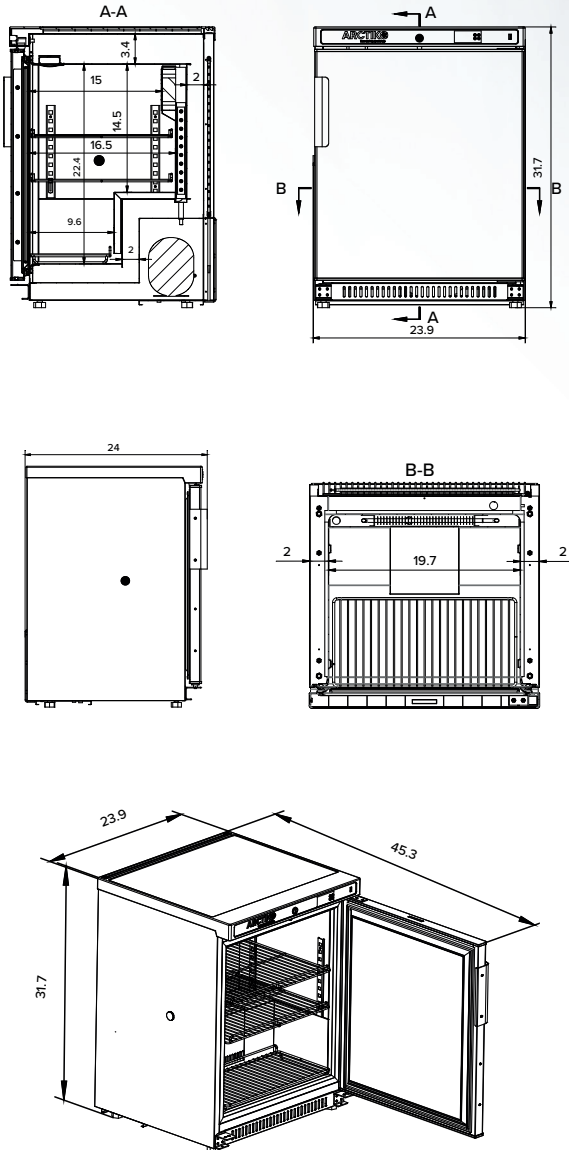

MODEL		LRE 125
Main specifications	Item code	1900025-01
	Temperature range (°C)	2°C to 8°C
	Ambient temperature (°C)	16°C to 32°C
	Capacity (L)	[121 / 109]
	Exterior dimensions WxDxH (mm)	608×610×805
	Interior dimensions WxDxH (mm)	500×450×570
	Weight (KG)	42
	Insulation (mm)	50
	Cooling technology	Air-forced
	Controller model / probe type	Honker / NTC
Power	Power supply (V)	230
	Frequency (Hz)	50/60
	Power consumption (kWh/24h)	1,9
	AMP (A)	1,0
	Power (Watt)	131
	Horsepower (HP)	1/6
Alarm functions	Alarm (displayed as text, not codes)	No
	Visual / acoustic alarm	Yes / Yes
	Power failure alarm	Yes
	Adjustable high / low-temperature alarm	Yes / Yes
	Open door alarm	Yes
	Probe failure alarm	Yes
	Low battery alarm	Yes
	Compressor failure alarm	No
Data logging & external connection	Voltage-free contact for remote alarm (e.g. GSM alarm module)	Yes
	Electronic data logger	Yes
	USB port for software update & data download	Yes
	Temperature chart recorder	No
Display features	Display type	Digital
	Number of optional reference probes	N/A
	Password protection for turning unit on / off	No
	Temperature graph on display	No
Other features	Automatic defrost	Yes
	Antifreeze function	Yes (2°C)
	Vacuum release port	No
	Access port for external probe etc. (int. diameter mm)	20
	Light	Yes
	Lock with key	Yes
	Castors (total pcs) / castors with brake (pcs)	No
	Fixed feet (pcs) / levelling feet (pcs)	4 / 4
	Sub lids / inner doors (pcs)	No
	Reversible door(s)	Yes
	Fixed shelves (pcs) / adjustable shelves (pcs)	0 / 3
	Max. no. of shelves (pcs) / recommended max. no. of shelves (pcs)	3 / 3
	Max load per shelf (kg)	19
Adjustable drawers (pcs)	N/A	
Max. no. of adjustable drawers (pcs)	N/A	
Max. load per adjustable drawer (kg)	N/A	
Max. no. of blood bags - by standard no. of adj. drawers (pcs)	N/A	
Max. no. of blood bags - by max. no. of adj. drawers (pcs)	N/A	
Refrigeration & cabinet	Number of compressors	1
	Refrigerant	R600a
	Interior cabinet material	Powder coated aluminum plate
	Exterior cabinet material	Powder coated galvanized steel
	Colour (exterior cabinet)	White
	Foam type	Cyclopentane
Shipping	VIP vacuum insulated panels	No
	Shipping weight (kg)	50
	Shipping dimensions WxDxH (mm)	650×664×872
	Shipping volume (m³)	0,4